

Industrial ironers

IC43316, IC43320



Images shown are a representation of the product only and variations may occur.

Features and benefits

- Easy to use control panel
- Ergonomic working height
- Finger guard protection providing additional security for operators
- Pressure roll with a Nomex ® padding for a good ironing quality
- Durable ironing belts made of Nomex ® which can withstand temperatures above 220°C
- Stainless steel cylinder prevents rust and improves lifetime
- **Maintenance free ceramic gas burner** minimizes downtimes. 20% more efficient than regular blue flame burners. A unique and patented burner by Electrolux
- Return feed, can be installed close to a wall for space saving
- Foldable feeding tray so that large flats avoid touching the ground

Main options

- Electronic control panel with automatic speed regulation system (DIAMMS*) – compatible with the RABC** process for the traceability of ironing parameters; flashing light showing to the operator that an item is not fully dried.
- CMIS*** connection for an automatic recording of the ironing parameters
- Nickel-plated cylinder for better production on cotton items
- Manual folding arm for easy folding of large flat items by only one operator
- Clutch to control the feeding belts for payment system control (excludes the payment system)

Main specifications			IC43316	IC43320
Capacity, max. water evaporation****		l/h	19.5	24.5
Cylinder	diameter	mm	325	325
	length	mm	1650	2065
Ironing speed		m/min	0.5-5.5	0.5-5.5
Heating	electricity	kW	18	22.5
	gas	Btu/h (kW)	68 240 (20)	85 330 (25)

* Direct Ironer Advanced Moisture Management System

** Risk Analysis and Bio-contamination Control

*** Certus Management Information System

**** 50% residual moisture content cotton 190 gr/m² and 100% cylinder use (ISO 9398)

Electrical connections*		IC43316	IC43320
Heating Voltage	380-415V 3AC 50/60 Hz		
Electric kW(A)		18 (32)	22.5 (40)
Gas	220-240V 3AC 50/60 Hz kW(A)	0.5 (12)	0.5 (12)
	380-415V 3AC 50/60 Hz kW(A)	0.5 (12)	
Gas and exhaust connections			
Gas	DN	20	20
Exhaust	outlet diameter	mm	125
	evacuated air	m3/h	426
515			
Sound levels			
Airborne sound level	dB(A)	65	65
Heat emission			
% of installed power, max		2	2
Weight**			
	net, kg	300	330
Shipping volume	m3	2.7	3.2
Dimensions in mm			
A	Width	2030	2445
B	Depth	690	690
C	Height	1145	1145
D	Gas connection height	430	430
1	Control panel	4 Main switch	
2	Electrical connection	5 Gas connection	
3	Exhaust connection		

* Other voltages available, see installation manual.

** Average data. Crated weight/shipping volume depends on configuration. Please contact logistics for exact measures.



Manual folding arm for easy folding of large flat items by only one operator

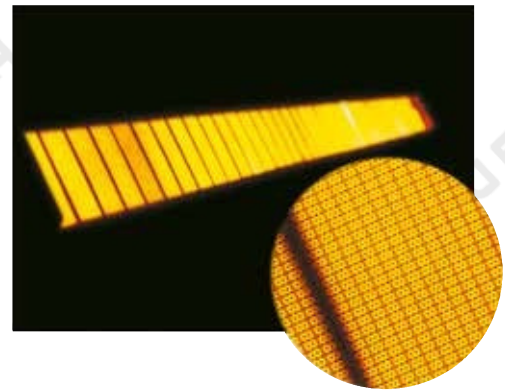

Maintenance free ceramic gas burner minimizes downtimes. 20% more efficient than regular blue flame burners. A unique and patented burner by Electrolux

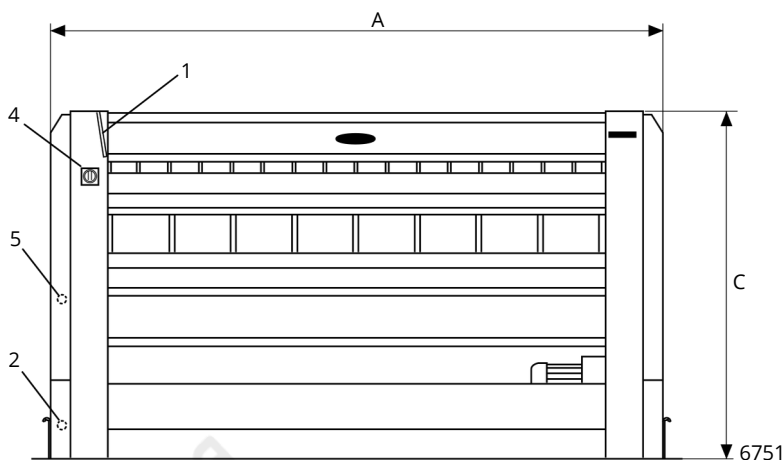

Front view

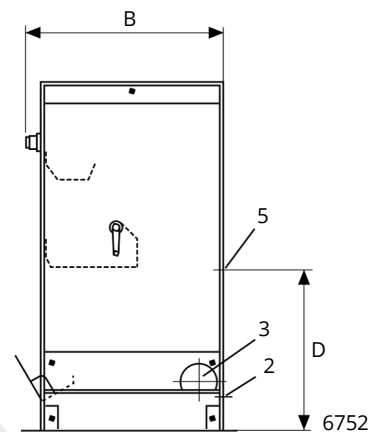

Right side view