

Industrial Ironers

IC64821LF, IC64825LF, IC64832LF



4 stars Ergonomic Certification



Certified ergonomics

Reducing workload, easing stress, intuitive and user friendly



Optimum productivity

Brilliant results with optimised staffing costs maintaining strict standards of hygiene



Full flexibility

Multiple solutions designed for your specific needs



Tried & tested durability

Guaranteeing consistent results without interruption



Images shown are a representation of the product only and variations may occur.

OPTIONS & AREA CONCERNED BY THE OPTIONS LF Model - Electric and Gas heated		Active	Performance	Superior
Manual Feeding:				
Feed Alone + Vacuum Table	Stop the feeding table (while you are still ironing) to feed alone large item	No	No	Yes
Vacuum Table	To optimise the feeding and by consequence the ironing quality	No	Yes	No
Folding:				
Antistatic Bar	To avoid polyester to stick on the cylinder	No	No	Yes
Productivity:				
Feed Now	To inform operator when and which area the ironer cylinder is ready to iron	Yes	No	No
Dubixium	Keep the cylinder temperature always uniform and optimise the productivity	No	Yes	Yes
DIAMMS	Operates automatically at optimum speed whilst perfectly managing the moisture in your laundry	No	Yes	Yes

OPTIONS & AREA CONCERNED BY THE OPTIONS LF Model - Steam heated		Active	Performance	Superior
Manual Feeding:				
Feed Alone + Vacuum Table	Stop the feeding table (while you are still ironing) to feed alone large item	No	No	Yes
Vacuum Table	To optimise the feeding and by consequence the ironing quality	No	Yes	No
Folding:				
Antistatic Bar	To avoid polyester to stick on the cylinder	No	No	Yes
Productivity:				
DIAMMS	Operates automatically at optimum speed whilst perfectly managing the moisture in your laundry	No	Yes	Yes

Main specifications		IC64821LF	IC64825LF	IC64832LF
Capacity*,	max. water evaporation** l/h	40/63/37	48/75/46	59/93/59
Cylinder, diameter (el, gas/steam)	mm	479/457	479/457	479/457
	length	2120	2540	3170
Ironing speed	m/min	1.5-9	1.5-9	1.5-9
Heating,	electricity	37	44	54
	steam (900 kPa)	92	110	141
	gas	Btu/h (kW)	150100(44)	177400(52)
* 50% residual moisture content cotton 180g/m ² and 100% cylinder use (ISO 9398-1).				
** El/steam/gas.				

Electrical connections*		IC64821LF	IC64825LF	IC64832LF
Heating alternative				
Electric heated 400-415V 3AC 50/60 Hz kW(A)		38 (63)	45 (80)	56 (100)
Gas heated / 208-240V 3AC 60 Hz kW(A)		2 (16)	2 (16)	2 (16)
Steam heated 400V 3 AC 50/60 Hz kW(A)		2 (16)	2 (16)	2 (16)
Steam, gas and air connections				
Steam	DN	20	20	20
Rec. steam pressure	kPa	900	900	900
Condensate	DN	10	10	10
Gas	DN	20	20	20
Gas pressure,	Pa	2000/2500	2000/2500	2000/2500
natural gas (G20/G25)	Pa	3700/5000	3700/5000	3700/5000
propane (G31)	ø mm	150	150	150
Air outlet	m ³ /h	830	950	1010
Evacuated air,	m ³ /h	740	880	960
gas		200	200	200
el, steam				
Pressure drop	max. Pa			
Sound levels				
Airborne sound level	dB(A)	73	73	73
Heat emission				
% of installed power, max.		3	3	3
Shipping data**				
Shipping volume	net, kg	1080	119	1390
Dimensions in mm A	m ³	5.63	0	7.64
Overall width			6.43	
B Ironing width		2785	3205	3835
1 Control panel		2120	2540	3170
2 Exhaust connection		4 Condensate connection		
3 Steam connection		5 Electrical connection		
		6 Gas connection		

* Other voltages available, see installation manual.

** Average data. Crated weight/shipping volume depends on configuration. Please contact logistics for exact measures.

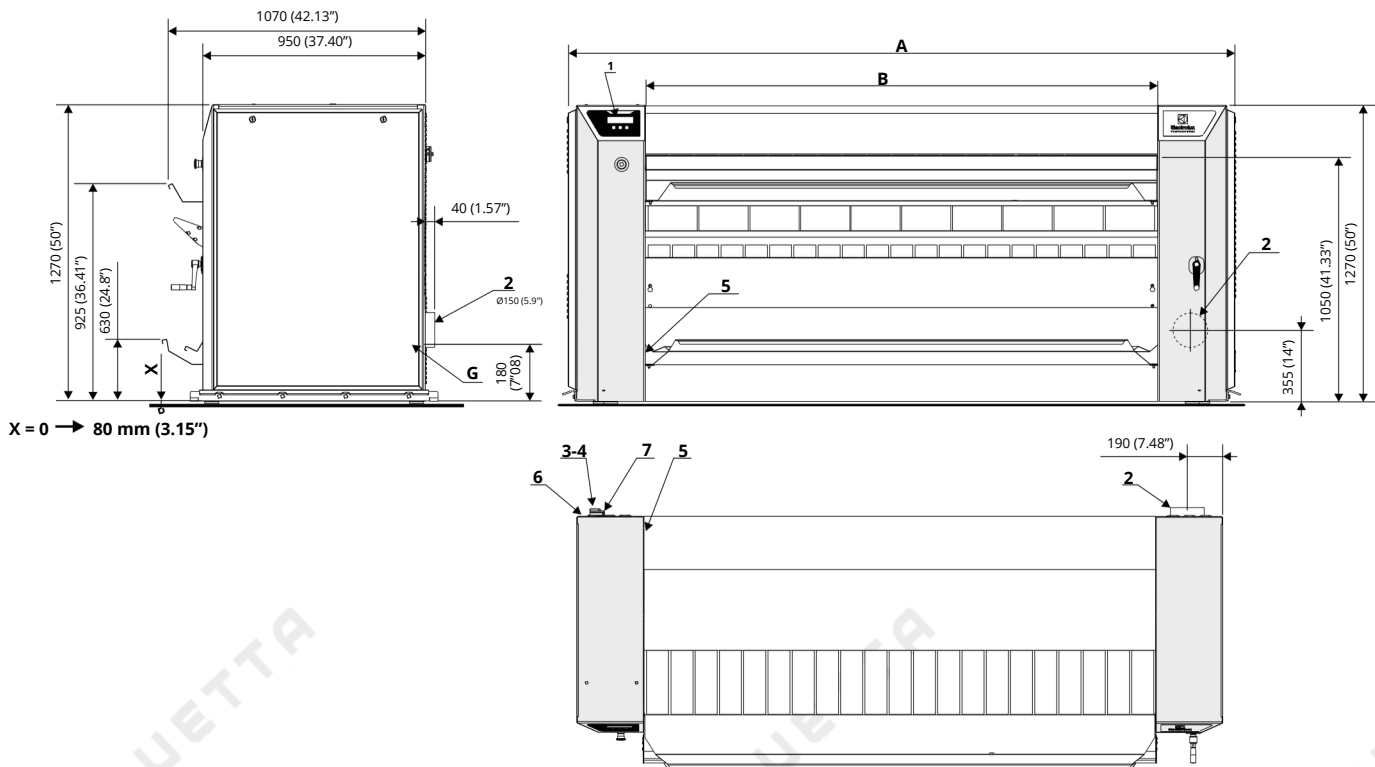

X = 0 → 80 mm (3.15")

